

ES2632M

MICRO-SIZED ELECTRIC SCISSOR LIFT

SCISSOR LIFT



KEY SPECS

Max Platform Height

25-ft 6-in / 7.77-m

Platform Capacity

600 lb / 272-kg

Number of Occupants

Indoor: 2*
Outdoor: 1

Stowed Drive Speed

3.0 mph / 4.8 km/h

KEY FEATURES

- Access tight spaces while experiencing exceptional maneuverability featuring a zero turn radius, compact footprint.
- Protect delicate work surfaces with the standard leak containment system consisting of custom-fit trays to capture potential leaks.
- Maximize productivity and uptime with onboard technology exclusive to JLG including Variable Tilt, Progressive Elevated Drive and ClearSky Smart Fleet.
- Optimize versatility with the ability to configure the machine with an integrated mid-rail deck, offering an additional 19.5-in height in the platform.

ACCESSORIES & OPTIONS

- 900W Inverter
- Additional Single Amber Beacon
- Anti-Vandalism Package
- Batteries, 4 X 6V 220 amp-hr AGM
- Batteries, Lithium Ion
- Coiled Platform Control Box Cable
- Hostile Environment Package
- Integrated Mid-Rail Deck (Additional 19.5-in Height)
- MDI (Ground)
- Special Hydraulic Fluids
- White Noise Alarm

*When optional integrated mid-rail deck is in use, only one occupant.

STANDARD SPECIFICATIONS

Performance	Indoor	Outdoor
Platform Height (Elevated)	25-ft 6-in / 7.77-m	18-ft / 5.49-m
Platform Capacity	600 lb / 272-kg	600 lb / 272-kg
Capacity on Platform Extension*	265-lb / 120-kg	265-lb / 120-kg
Number of Occupants	2	1
Lift / Lower Time (No Load)	25-35 Seconds	25-35 Seconds
Lift / Lower Time (Rated Load)	26-34 Seconds	26-34 Seconds
Maximum Drive Height	Fully Elevated	Fully Elevated
Weight*	4,560-lb / 2,068-kg	4,560-lb / 2,068-kg
Max. Ground Bearing Pressure	192 psi / 13.5 kg/cm ²	192 psi / 13.5 kg/cm ²
Drive Speed (Lowered)	3.0 mph / 4.8 km/h	3.0 mph / 4.8 km/h
Drive Speed (Raised)	0.5 mph / 0.8 km/h	0.5 mph / 0.8 km/h
Max Gradeability	24%	24%
Max Tilt Rating (Side-to-Side)	1.5 Degrees	1.5 Degrees
Max Tilt Rating (Fore and Aft)	3.0 Degrees	3.0 Degrees
Turning Radius (Inside)	Zero	Zero
Turning Radius (Outside)	66-in / 1.68-m	66-in / 1.68-m

Certain options or country standards increase weight.
*Standard Machine Without Integrated Mid-Rail Deck.

Power

Batteries	4 X 6V 220 Amp
Charger	650W Delta Q
Drive	24V AC

Tires

Standard	12.7 in / 323 x 100-mm, Non-Marking
----------	-------------------------------------

Brakes

Electric, friction

Hydraulic System

Capacity	1.3 gal / 5 L
Pump	Fixed Displacement Gear

STANDARD FEATURES

- 27 amp Multi-Function Universal Charger
- 110V AC Receptacle in Platform
- Active Pothole Protection System
- All Motion Alarm
- Analyzer Port for Diagnostics
- Battery Condition Indicator
- CAN-Enabled Charger
- ClearSky Smart Fleet™ Hardware (CS550)
- Diamond Tread Steel Deck
- Drive Motor Covers
- Electric Drive
- Foot-Actuated Deck Extension
- Fork Lift Pockets
- Greaseless Kingpin Joints
- Horn
- Hourmeter
- Lanyard Attach Points
- Leak Containment System
- LED Motion/Amber Beacon (CS550)
- Lifting and Tie Down Points
- Load Sensing System
- Lubrication Free Scissor Arm Bushings
- Manual Descent Cable
- Movable, Removable Platform Control Box
- Nickel Plated Pins
- Progressive Elevated Drive
- Proportional Controls
- Quick Fold Rails
- Removable Ladder
- Scissor Maintenance Prop
- Self-Closing Gate
- Steel Swing-Out Doors
- Tilt Alarm and Light
- USB Charger & Phone Holder
- Variable Tilt Visual Zone Indicator

ES2632M

MICRO-SIZED ELECTRIC SCISSOR LIFT

SCISSOR LIFT



DIMENSIONS

All dimensions are approximate

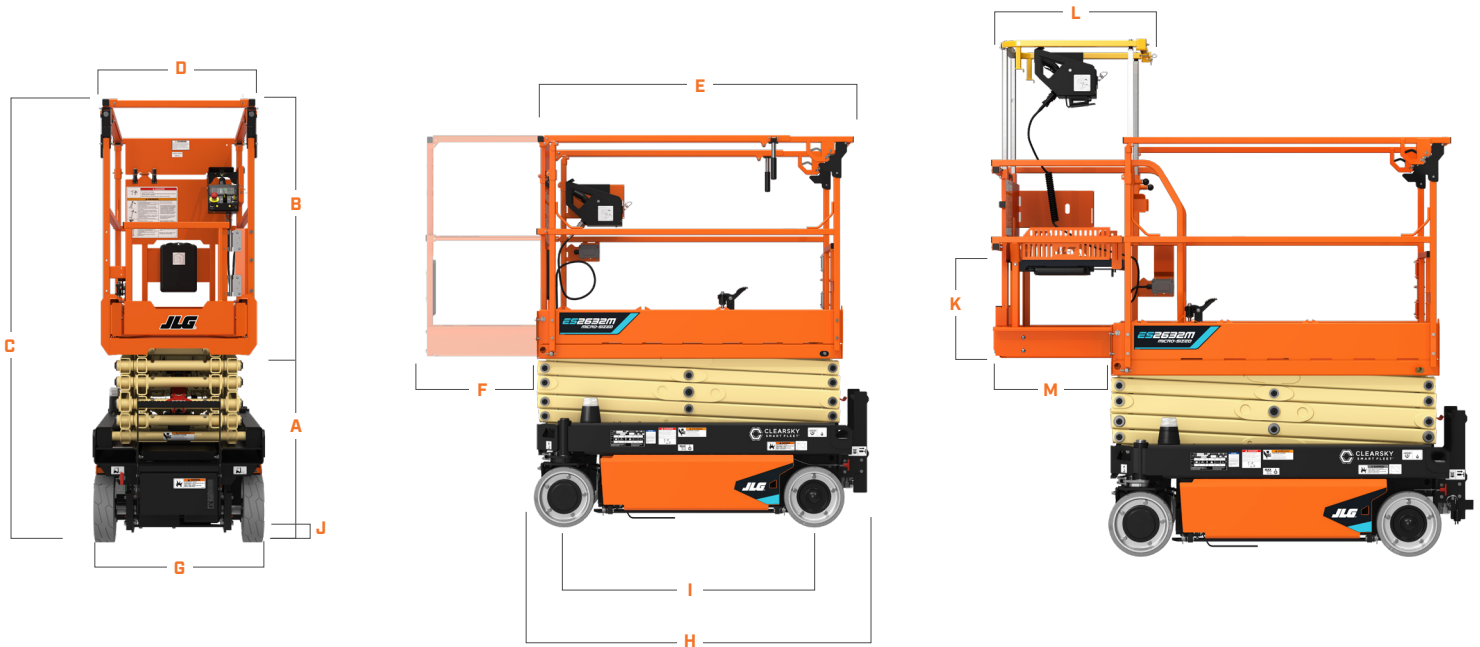

A. Platform Height (Lowered)	38.7-in / 98-cm
B. Platform Railing Height	43.3-in / 1.10-m
C. Machine Height (Rails Raised)	83.1-in / 2.11-m
D. Platform Width	25.4-in / .64-m
E. Platform Length	62.7-in / 1.59-m
F. Platform Extension	33.7-in / 86-cm

G. Machine Width	32-in / 81-cm
H. Machine Length	72.3-in / 1.84-m
I. Wheelbase	53-in / 1.34-m
J. Ground Clearance	2.8-in / 7-cm

OPTIONAL: Integrated Mid-Rail Deck

K. Integrated Mid-Rail Deck Height	19.5-in / 50-cm
L. Integrated Mid-Rail Deck Platform	22 x 23-in / 56 x 58-cm
M. Integrated Mid-Rail Deck Platform Extension	23.7-in / 60-cm



We provide coverage for one (1) full year, and cover all specified major structural components for five (5) years. Due to continuous product improvements, we reserve the right to make specification and/or equipment changes without prior notification. This machine meets or exceeds applicable ANSI and CSA requirements based on machine configuration as originally manufactured for intended applications. Please reference the serial number plate on the machine for additional information.



JLG INDUSTRIES, INC.
Toll-free US 877-JLG-LIFT
JLG.com

An Oshkosh Corporation Business